

Specifications

Chuck Model	Spindle Nose	Collet Model	Accuracy Max Radial	Collet Capacity	Collet Clamp	Chuck Stroke	Max Draw Tube Force	Max Clamping	Max Speed	Chuck Weight
CB80-NX/A6	A2-6	80BZI	.0004"	3.250"	+/- .020"	.160"	11,240 lbs	25853 lbs	5,500 rpm	35.6 lbs
			0.010mm	82.5mm	0.5mm	4mm	50 kN	115 kN		16.1 kg

Dimensions

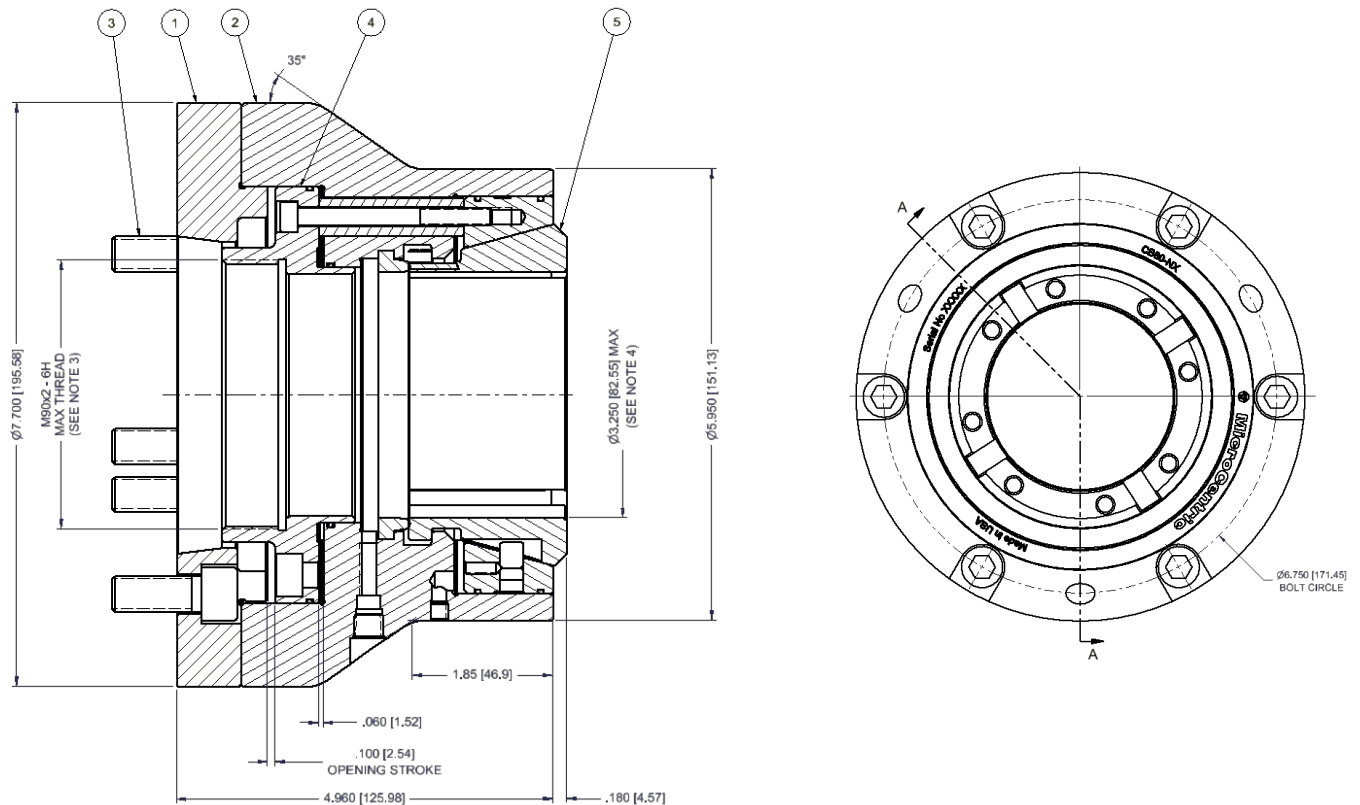

ITEM	QTY	PART NUMBER	DESCRIPTION
1	1	16 080 107	ADAPTER
2	1	16 080 200	FITTED BODY AND SLEEVE
3	6	83 194 M030	M12 x 30 SHCS
4	1	SEE NOTE 3	DRAW TUBE CONNECTOR
5	1	SEE NOTE 4	COLLET

NOTES

- DIMENSIONS SHOWN ARE FOR REFERENCE ONLY.
- THE CHUCK IS SHOWN IN THE NOMINAL CLAMPED POSITION.
- DRAW TUBE CONNECTOR AND THREAD PER CUSTOMER REQUIREMENTS.
- THE CHUCK IS SHOWN WITH THE MAX COLLET BORE.